

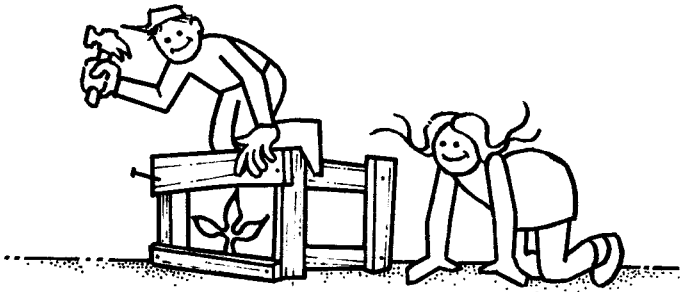

MAKING A SIMPLE GREENHOUSE



THE FIRST POINT TO BE DECIDED IS WHERE TO BUILD YOUR GREENHOUSE ! PLEASE READ AGAIN CHAPTER 3, "HOW TO MAKE GROW-BOXES". THAT CHAPTER DEALS IN DETAIL WITH LOCATION AND THE SAME INFORMATION APPLIES TO GREENHOUSES. REMEMBER - YOU CAN BUILD OVER ALMOST ANY KIND OF SURFACE IF IT CAN BE LEVELED TO ACCOMMODATE THE GREENHOUSE.

THE STANDARD-SIZE MITTLEIDER GREENHOUSE IS 8 FEET WIDE , 30 FEET LONG , AND 10 FEET HIGH. YOU CAN BUILD ANY SIZE , OF COURSE , TO FIT YOUR PATIO , YARD , OR OPEN AREA ! A TYPICAL MITTLEIDER GREENHOUSE REQUIRES NO SPECIAL LABORATORY EQUIPMENT, PUMPS , FANS , PH METERS , TANKS , OR COOLING PADS.

IF SEVERAL GREENHOUSES ARE CONSTRUCTED, SEPARATE THEM 6 FEET AT THE ENDS AND SIDES. THIS IS ESSENTIAL FOR ADEQUATE LIGHT AND AIR.

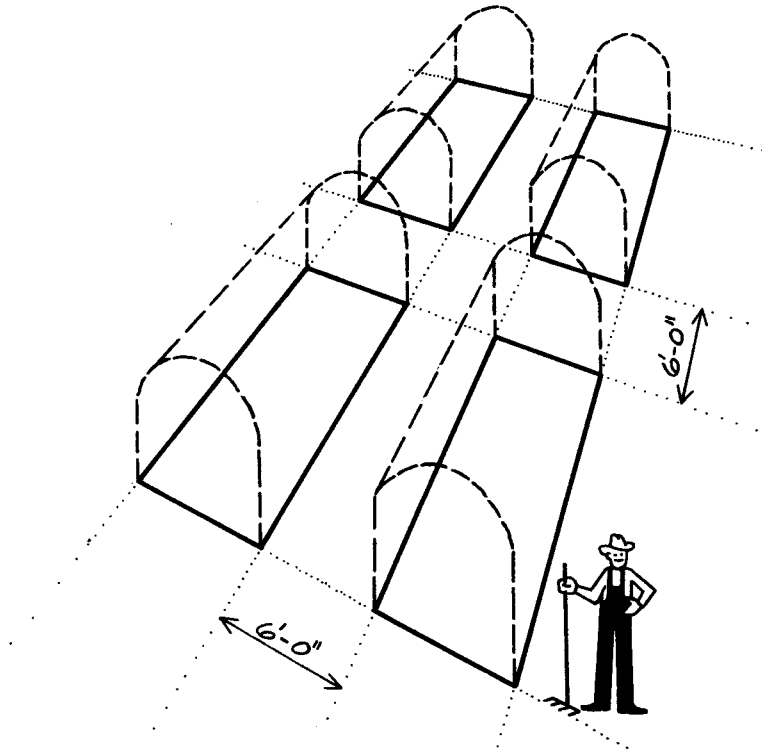

AN AREA 28 FEET BY 42 FEET WILL HOLD FOUR STANDARD-SIZE GREENHOUSES. MORE THAN ADEQUATE TO SUPPLY ALL THE FRESH PRODUCE FOR YOUR FAMILY. A FAMILY CAN HAVE FRESH PRODUCE AND BE ECONOMICALLY SELF-SUFFICIENT ON THE INCOME FROM 10 GREENHOUSES. THIS CAN BE ACCOMPLISHED ON AN AREA OF ONLY 5,000 SQUARE FEET ($\frac{1}{8}$ ACRE)! IF YOU ARE THINKING BIG, ONE ACRE OF LAND ACCOMMODATES 86 STANDARD-SIZE GREENHOUSES!

HERES HOW TO MAKE THE STANDARD
MITTLEIDER GREENHOUSE

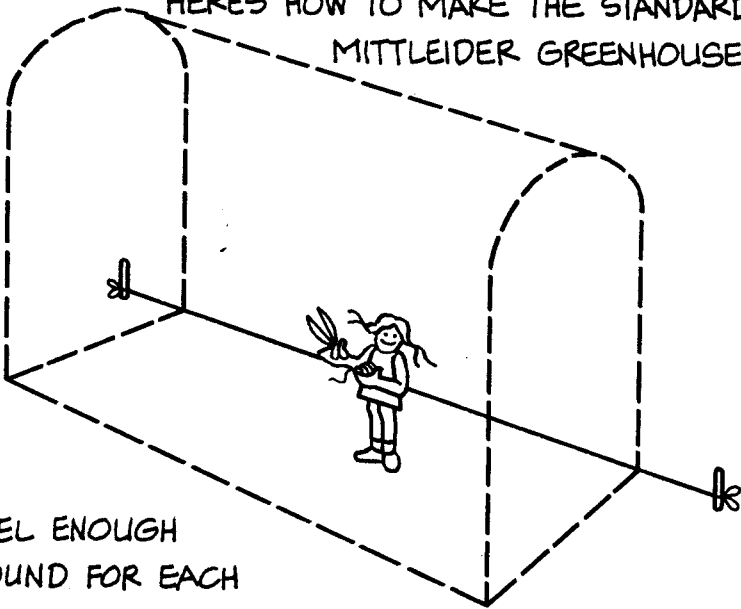

LEVEL ENOUGH
GROUND FOR EACH
GREENHOUSE. USE STAKES, CORD, SQUARE, AND
LEVEL TO LINE UP YOUR GREENHOUSE STRAIGHT-
BOTH LENGTH AND WIDTH- AND TO CONSTRUCT IT
PLUMB. STRETCH THE CORD AND TIE IT TO STAKES
THE LENGTH OF ONE SIDE OF THE GREENHOUSE PLOT.

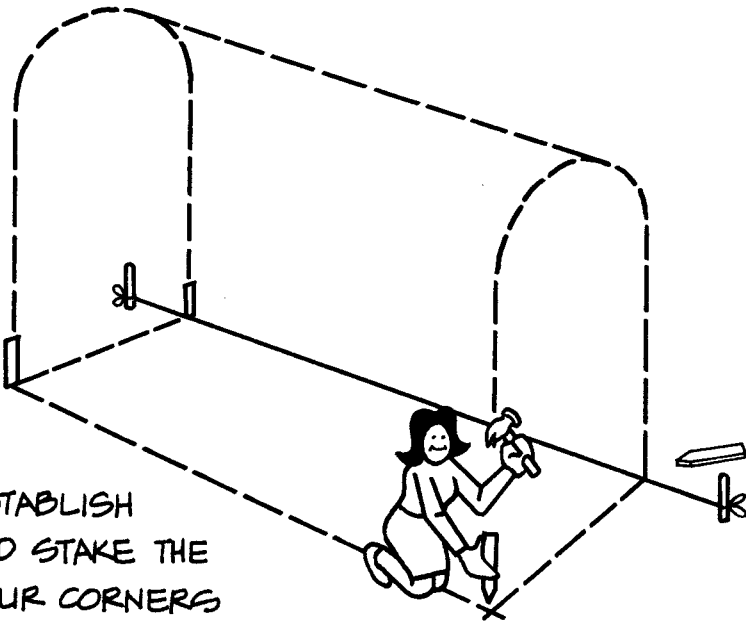

ESTABLISH
AND STAKE THE
FOUR CORNERS
OF THE GREENHOUSE.

MEASURE AND CUT
TO LENGTH, EIGHT
REDWOOD (OR CEDAR)
4"x4" POSTS
9 FEET LONG.
MEASURE AND
MARK 18 INCHES
FROM ONE END
OF EACH OF THE
POSTS. THIS IS THE
PORTION OF THE POST TO BE
EMBEDDED IN THE GROUND.

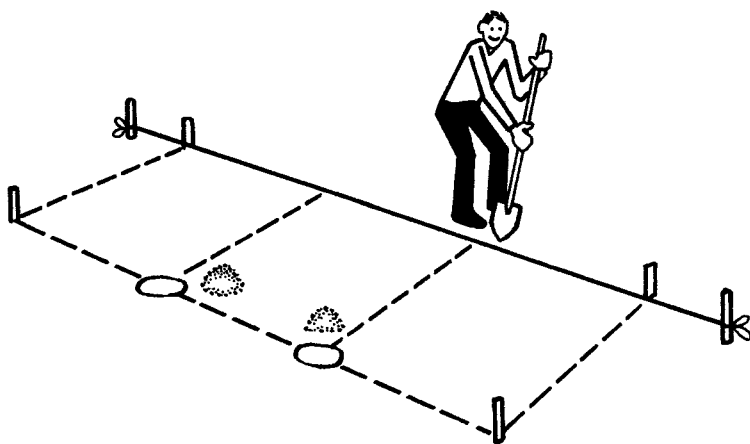
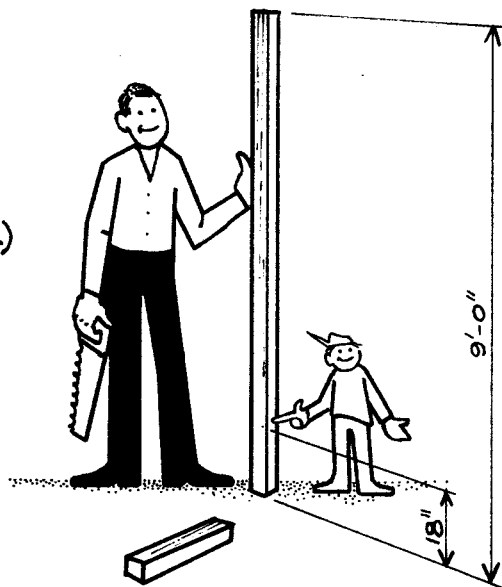

DIG EIGHT HOLES 18 INCHES DEEP WHERE
THE 4"x4" POSTS WILL BE SET.

LOWER A 4"x4" POST INTO CORNER HOLE (a) TO THE 18-INCH MARK. USE LEVEL TO PLUMB THE POST (MAKE IT VERTICAL), THEN TAMP IT FIRMLY INTO PLACE WITH DIRT. THE SECOND POST TO SET IS THE OPPOSITE CORNER (b); BUT BEFORE SETTING THIS POST TIGHT, YOU MUST ESTABLISH THE LEVEL OF THE GREENHOUSE. DO THIS WITH A CORD, LEVEL, AND CARPENTER'S SQUARE, LIKE THIS:

DRIVE A NAIL (c) NEAR THE TOP OF POST (a). TIE THE CORD TO THIS NAIL.

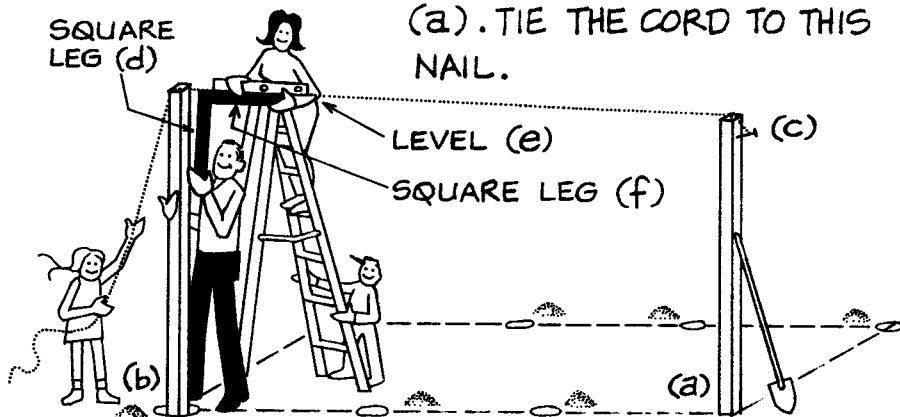

PULL THE CORD OVER THE TOPS OF POST (a) AND THE LOOSE POST (b), APPLYING ENOUGH TENSION ON THE CORD TO KEEP IT FROM SAGGING BETWEEN THE POSTS. HOLD THE SQUARE (d) FLAT AND SQUARE AGAINST THE LOOSE POST. LINE UP THE OTHER LEG (f) OF THE SQUARE WITH THE CORD. PLACE THE LEVEL (e) ON THIS "LEG" OF THE SQUARE.

IMPORTANT: KEEP THE "LEG" OF THE SQUARE (f) STRAIGHT WITH THE CORD AT ALL TIMES (BY MOVING THE TOP OF THE POST LEFT OR RIGHT). 101

RAISE OR LOWER THE POST (b) UNTIL THE LEVEL SHOWS "LEVEL" AND THE SQUARE "LEG" (f) IS PARALLEL WITH AND LEVEL WITH THE CORD. TAMP THE POST TIGHT WITH DIRT. IT IS PLUMB, VERTICAL, AND THE TOP OF THE POST (b) IS LEVEL WITH THE TOP OF THE POST (a).

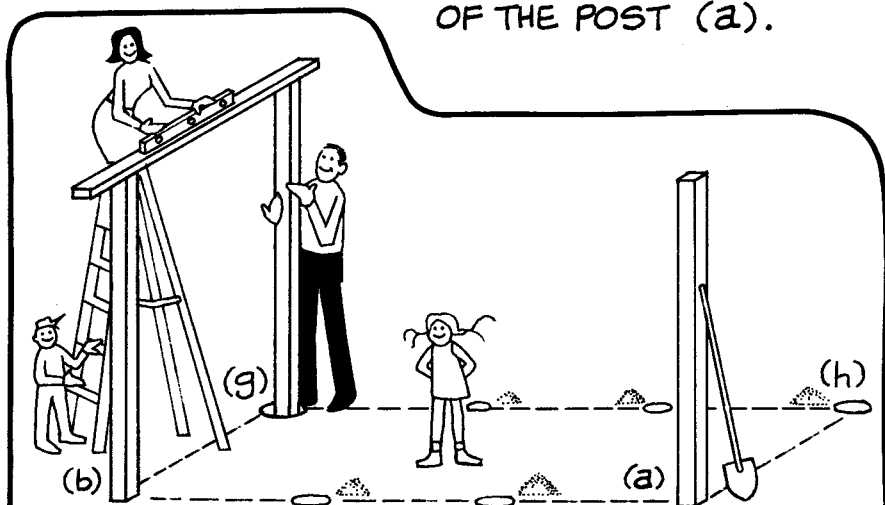

NEXT, LOWER POST (g) INTO THE HOLE AT THE CORNER ON THE OPPOSITE SIDE OF THE STRUCTURE. THE DISTANCE BETWEEN POSTS (b) AND (g) IS 8 FEET-INSIDE. PLACE A STRAIGHT, 2"x4"x10'-0" LONG BOARD ON TOP OF POSTS (b) AND (g). LAY THE LEVEL ON TOP OF THE 2"x4". RAISE OR LOWER POST (g) UNTIL BUBBLE IN LEVEL READS "LEVEL". NOW, WITH THE LEVEL, MAKE THE POST (g) VERTICAL AND TAMP IT FIRM AND SOLID. REPEAT THIS PROCESS AT THE OTHER END OF THE STRUCTURE, USING POST (a) TO SET POST (h) VERTICAL AND LEVEL.

THE FOUR CORNERS ARE ESTABLISHED, LEVEL, AND PLUMB. NOW SET THE SIDE POSTS (TWO ON EACH SIDE).

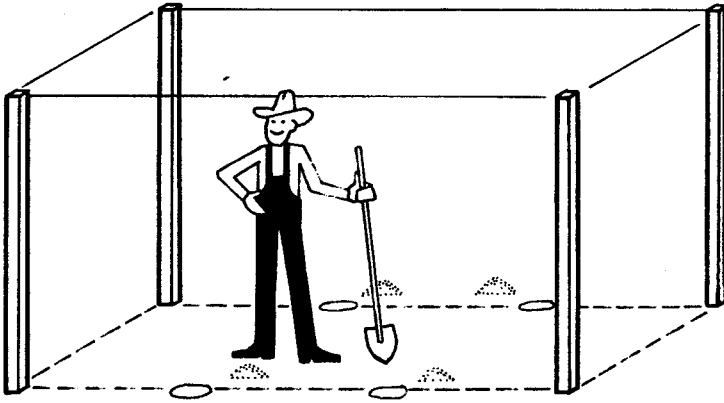

ON ONE SIDE OF THE STRUCTURE STRETCH A CORD (i) TIGHTLY FROM THE TOP OF ONE CORNER POST OVER THE TOP OF THE OTHER CORNER POST. RAISE OR LOWER THE SIDE POSTS (j) AND (k) UNTIL THEY TOUCH THE STRETCHED CORD OVERHEAD. PLUMB THE POSTS AND TAMP THEM TIGHT.

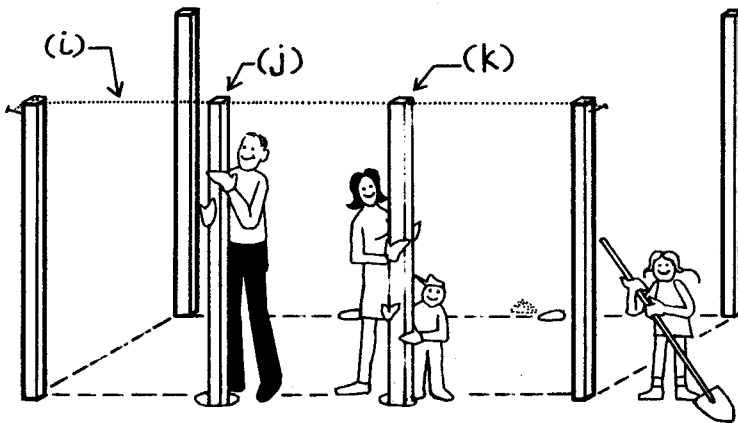

REPEAT FOR THE OTHER SIDE OF THE STRUCTURE. WITH THIS ACCOMPLISHED THE HARDEST PART OF BUILDING YOUR GREENHOUSE IS DONE. 103

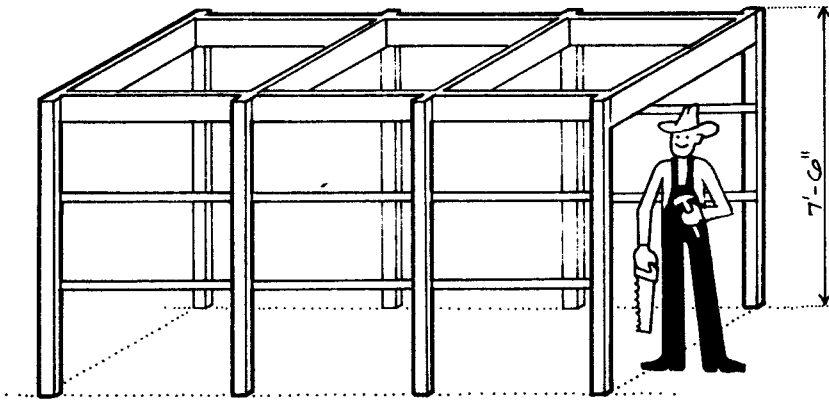

NAIL 2"x6" BOARDS AROUND THE INSIDE AT THE TOP OF THE POSTS AND ACROSS THE WIDTH BETWEEN THE POSTS. NOW JUST NAIL 1"x2" BOARDS SPACED 24 INCHES APART DOWN THE SIDES ALONG THE LENGTH.

INSTALLING GROW-BOXES

THE BASIC PROCEDURE OF LEVELING AND INSTALLING THE SIDES OF THE GREENHOUSE GROW-BOXES IS SIMILAR TO THAT DESCRIBED IN CHAPTER 3 ON OUTDOOR GROW-BOXES.

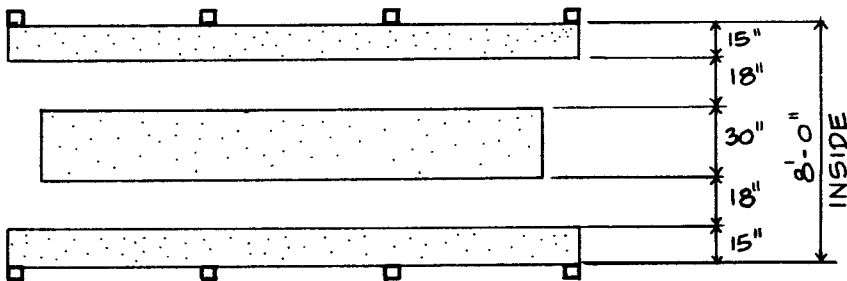

HERE IS A PLAN VIEW OF THE LAYOUT OF THE GROW-BOXES. THE SIDE BOXES ARE 15 INCHES WIDE, THE AISLES ARE 18 INCHES WIDE AND THE CENTER GROW-BOX IS 30 INCHES WIDE.

INSTALL 2"x4" FRAMING AS SHOWN AT THE ENDS FOR A DOOR OPENING. THE DOOR IS 30 INCHES WIDE. IT IS MADE UP OF 2"x2" FRAMING AND HINGED TO SWING FROM THE LEFT OUTWARD.

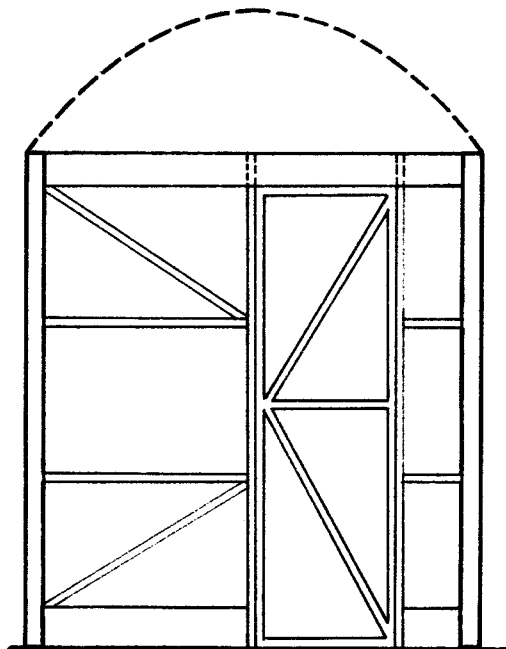

THE DOTTED LINES SHOW THE SUPPORT WIRES. THE WIRES RUN THE LENGTH OF THE GREENHOUSE OVER THE GROW-BOXES.

STRINGS THAT WILL SUPPORT THE VINES ARE TIED TO THESE WIRES.

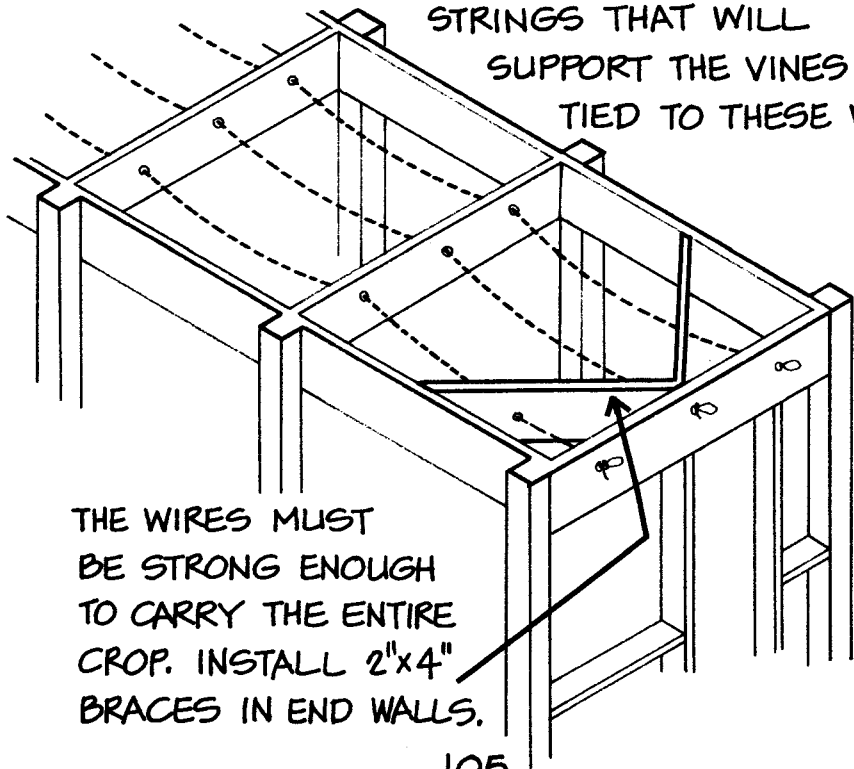

THE WIRES MUST BE STRONG ENOUGH TO CARRY THE ENTIRE CROP. INSTALL 2"x4" BRACES IN END WALLS.

THE WOOD FRAMING AND BRACING IS COMPLETE. NEXT IS THE PLACEMENT OF THE PLASTIC PIPE FOR THE CURVED ROOF. THE BASIC PROCEDURE FOR INSTALLING THIS PLASTIC PIPE IS SIMILAR TO THAT ALREADY DISCUSSED IN CHAPTER 9 ON GREENHOUSE-SHELTERED GROW-BOXES.

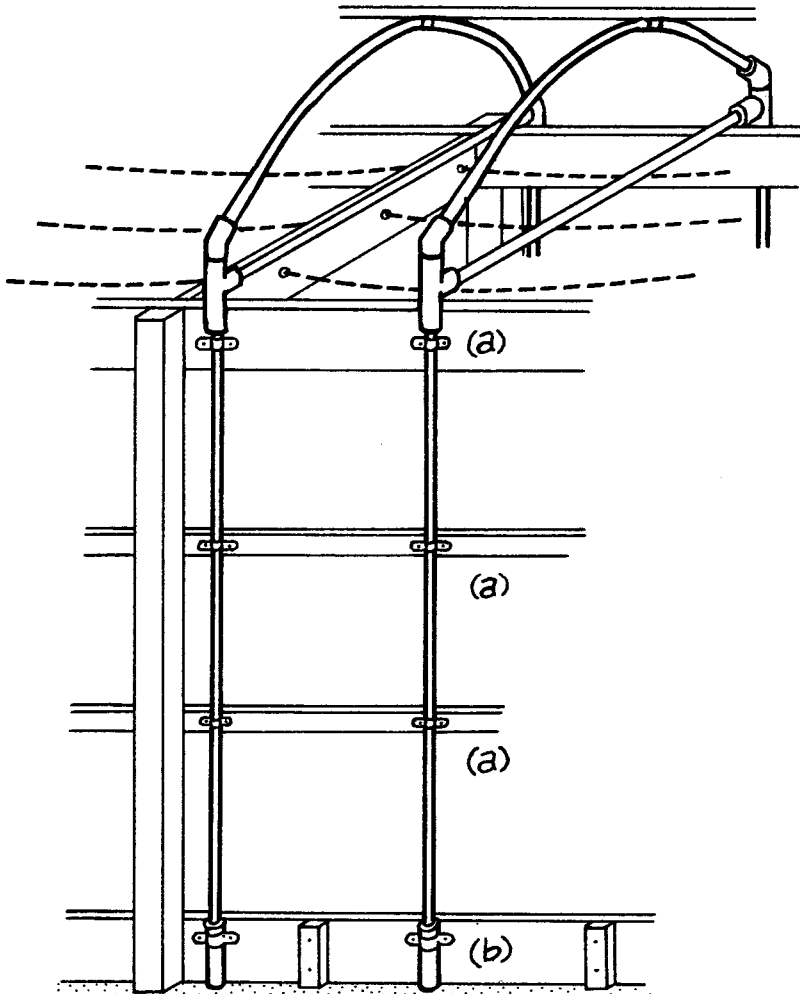

THE PLASTIC PIPE "LEGS" ARE FASTENED TO THE 1"x2"'S (a) ALONG THE SIDES AND TO THE SIDE OF THE GROW-BOX (b); USE METAL "U" CLAMPS. THE CURVED ROOF MEMBERS ARE CONNECTED TO THE 2"x2" AT THE RIDGE WITH "U" CLAMPS ALSO. 106

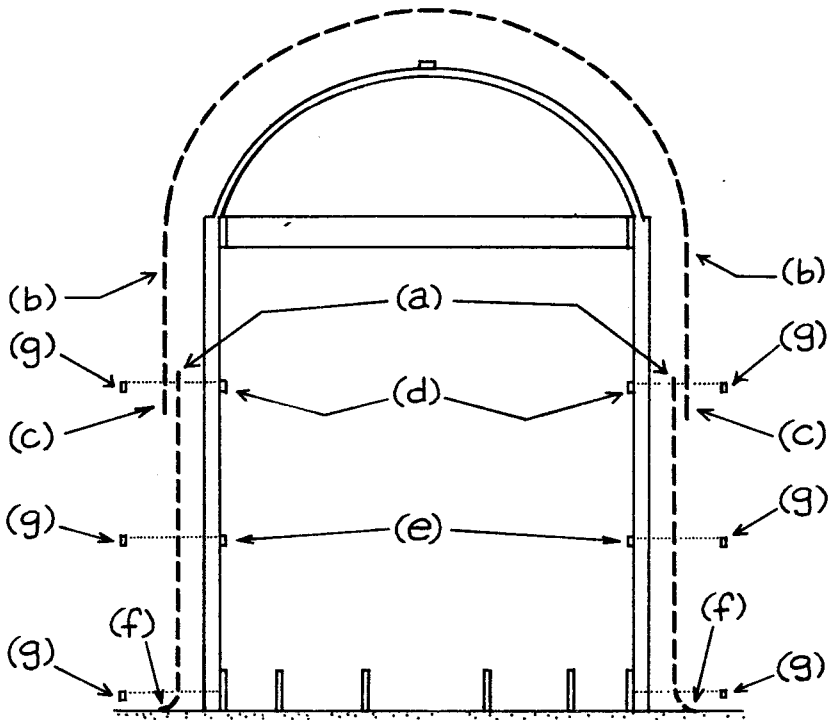

THIS CROSS SECTION INDICATES HOW TO COVER THE STRUCTURE WITH PLASTIC. FIRST, THE 6-FOOT-WIDE SIDE PIECES (a) ARE TACKED IN PLACE JUST ABOVE THE TOP 1"x2" STRIP (d) RUNNING ALONG BOTH SIDES OF THE GREENHOUSE. NEXT, THE 16-FOOT-WIDE PLASTIC TOP-PIECE (b) IS PULLED IN PLACE. THE TOP-PIECE OVERLAPS THE 6-FOOT SIDE-PIECE (c) - ON THE OUTSIDE (TO SHED RAIN). THE TWO PIECES OF PLASTIC (WHEN IN POSITION) ARE FIRST NAILED SECURELY TO THE TOP 1"x2" (d) ON BOTH SIDES OF THE STRUCTURE WITH LATH (g) AND THEN LATHED AND NAILED TO THE LOWER 1"x2" (e) ON BOTH SIDES. THE LOOSE EDGE OF THE PLASTIC ON THE GROUND (f) IS COVERED FIRMLY WITH SOIL THE ENTIRE LENGTH OF THE GREENHOUSE.

THE LATH STRIPS, FASTENING PLASTIC SECURELY TO THE 1"x2"s ON EACH SIDE, AND THE SOIL FIRMLY HOLDING THE PLASTIC TO THE GROUND ANCHOR YOUR PLASTIC COVERING SECURELY AGAINST RAIN AND HARD WINDS.

THERE ARE MANY MODIFICATIONS THAT CAN BE MADE ON THIS BASIC DESIGN. ONE IS REDUCING THE SIZE TO 5 FEET WIDE AND 10, 20, OR 30 FEET LONG-WITH ONLY TWO 15-INCH GROW-BOXES (ONE ON EACH SIDE) AND A 30-INCH AISLE IN THE MIDDLE.

ANOTHER CHANGE IS TO TAPER THE TOP ENDS OF THE 4"x4" POSTS TO MATCH THE CURVE OF THE ROOF. THIS HELPS TO PREVENT THE PLASTIC COVERING FROM TEARING WHEN ONLY ONE LAYER OF PLASTIC IS USED.

NOTE : FOR COLDER WEATHER THE BASIC STANDARD MITTLEIDER GREENHOUSE IS DESIGNED SO THAT IT MAY BE COVERED WITH TWO LAYERS OF PLASTIC WITH A 3-TO 4-INCH, DEAD AIRSPACE BETWEEN THE LAYERS (AN IMPORTANT ECONOMIC FACTOR WHEN HEATING THE GREENHOUSE IS NECESSARY). FOR FURTHER DETAILS ON "COLD WEATHER GARDENING" SEE CHAPTER 12.